



BOARD 'N BATTEN



# BOARD 'N BATTEN

SUPER POLYMER VERTICAL SIDING

## ADD VISUAL INTEREST TO ANY ARCHITECTURAL STYLE WITH **BOARD 'N BATTEN**

---

**ProVia® Board 'N Batten** recreates the classic vertical panel. As material and design choices continue to expand, BnB offers a versatile siding alternative. Use the striking dimensional finish of BnB as your home's primary exterior finish or to accent entryways, gables, porches, dormers or build-outs.

Historically a staple of Arts and Crafts architecture, Board 'N Batten is a centuries-old siding style that makes it easy to add distinctive details to your home. No matter the architectural style of your home – from Craftsman to Farmhouse to Victorian – BnB imparts a rustic, handmade quality even to new homes built in unmistakably contemporary styles.





**NEW**

# CEDARMAX<sup>®</sup> 12" BOARD 'N BATTEN

SUPER POLYMER INSULATED SIDING

- Wide 12" Design Provides a Minimalistic Look with Fewer Vertical Lines
- Only Available in White
- Super Polymer Formulation
- Maximum Energy Savings
- Greater Impact Resistance than Regular Siding
- Tri-Pigment Reflective Technology & Weather Barrier Shield
- Lifetime Limited Warranty



**NEW 12" BOARD 'N BATTEN**



**8" BOARD 'N BATTEN**



# CLASSIC STYLE, ENGINEERED TO PERFORM

The term "batten" refers to the strip of molding placed across the joint between boards. The resulting look boasts an attractive geometry of strong vertical lines balanced by a sense of texture across the horizontal face.

Faithful to its original design from centuries ago, these vertical panels feature:

- Standard: 6¼" board face and a 1¾" batten strip – a full 8" panel that is wider than comparable products
- Lifetime Limited Warranty
- Tested and certified to meet or exceed ASTM standards & VSI Product Certification
- .050" panel thickness for strength and durability

## 8" CEDARMAX®

- Backed with rigid EPS foam insulation increasing the total wall R-value of your home
- Super Polymer Formulation
- Maximum energy savings
- Greater impact resistance than regular siding
- Tri-Pigment Technology & Weather Barrier Shield
- 1½" overall insulated siding system thickness
- Able to withstand winds of 179 (mph, ASD)\*
- Standard Design Pressure Rating: 77.7 psf (ASD)\*
- 8" meets or exceeds ASTM D7793
- Lifetime Limited Warranty

## 8" CEDAR PEAKS®

- High windload performance
- Super Polymer Formulation
- Tri-Pigment Technology & Weather Barrier Shield
- Deep profile for increased shadow lines
- Able to withstand winds of 144 (mph, ASD)\*
- Standard Design Pressure Rating: 50 psf (ASD)\*
- Meets or exceeds ASTM D3679
- Lifetime Limited Warranty

\*Rating per VSI Wind Speed Calculation Guidelines

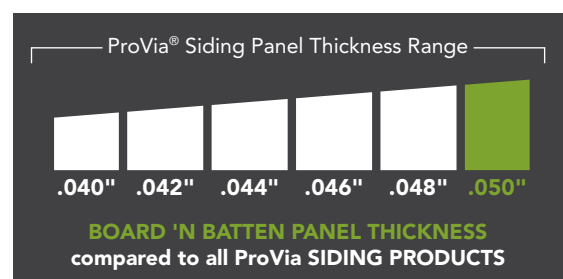

# WHAT'S INSIDE SUPER POLYMER?

A strong molecular chain that provides

**superior color retention +**

**weather resistance**

ProVia® Super Polymer formulation is comprised of our Tri-Pigment Reflective Technology, Weather Barrier Shield, SPX-2000 UV Protection and Color Keeper Anti-Fade Protection. Inorganic materials, anti-weathering ingredients, butyl and acrylic modifiers are melded together to create a strong molecular chain for superior color retention and weather resistance.



## SUPER POLYMER MEANS PEACE OF MIND

knowing your home is clad in the industry's best vinyl siding



### Tri-Pigment Reflective Technology

- A precise formulation of heat resistant inorganic pigments ensuring exacting deep colors.
- Reflects heat away from exterior walls and deflects damaging infrared solar rays to reduce solar heat build-up and unsightly weathering.



### Weather Barrier Shield

- A concentration of precisely formulated anti-weathering materials at the product surface.
- Helps ensure long-lasting color fidelity and maintenance freedom for your home's exterior.



### SPX-2000 UV Protection

- Helps block the destructive effects of the sun's UV rays.

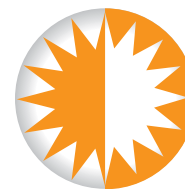

### Color Keeper Anti-Fade Protection

- Meticulously engineered with the finest mix of ingredients that build a stronger molecular chain for superior color retention.

# BOARD 'N BATTEN COLORS

## LIFESTYLE COLLECTION



## SIGNATURE COLLECTION

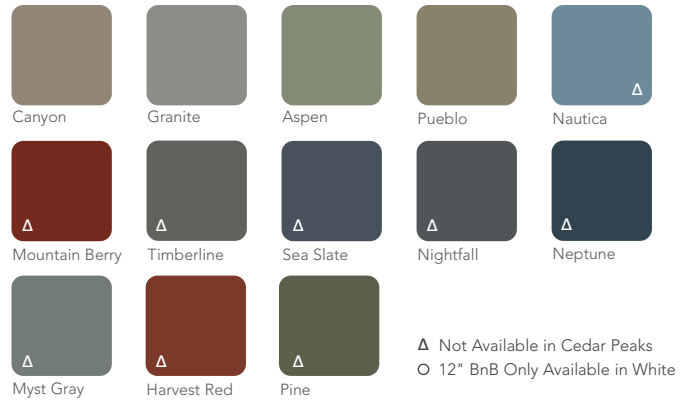

### CEDARMAX® Coordinating Accessories

Available for 8" and 12" profiles

- Soffit (Center Vent, Full Vent & Hidden Vent)
- 1 1/8" J-Channel
- 1 1/8" Inside Corner Post
- 1 1/8" Outside Corner Post with 3 3/4" or 5" Face
- 1 1/8" Window/Door Surround with 3 1/2" Face
- 1 1/8" Transition Trim with 5" Face
- Undersill Trim
- Starter Strip

### CEDAR PEAKS® Coordinating Accessories

- Soffit (Center Vent, Full Vent & Hidden Vent)
- 5/8" or 3/4" J-Channel
- 3/4" Inside Corner Post
- 5/8" or 3/4" Outside Corner Post with 3 3/4" Face
- Designer Brick Mold/J-Channel
- 3/4" Window/Door Surround with 3 1/2" Face
- 3/4" T-Trim Molding
- Undersill Trim
- Starter Strip

## COMPLETE THE LOOK!



Complete the look of your home's exterior by coordinating Board 'N Batten vertical siding with ProVia® extensive portfolio of products.



# VINYL SIDING. NO LIMITS.

## THE TOP 6 REASONS TO SIDE WITH VINYL

Vinyl siding is the most popular home cladding material on the market today because of its ease of maintenance, many profile and color options, long-term beauty and affordability. Add that to strong contractor training programs that help assure quality installations, and it's easy to see how vinyl siding means you won't have to compromise. When choosing ProVia® siding for your home, you'll discover a portfolio of professional-grade products to best fit your needs and architectural style.

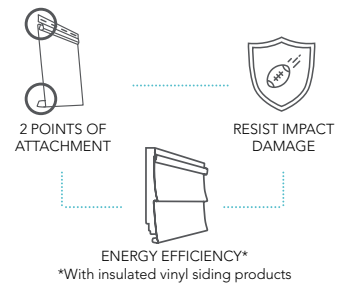
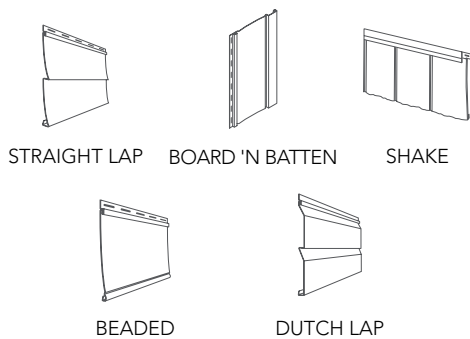

**1 If you can dream it, vinyl siding can bring it to life.** A virtually endless range of ProVia® styles, colors and textures allows you to coordinate with any architectural style or personal taste.

**2 It's easy to create the complete look.** ProVia® complementary accessories let you add the finishing touches to any design with all the benefits of our vinyl siding.

**3 Engineered for life.** ProVia's exclusive Super Polymer formulation uses the highest-grade ingredients to deliver high-impact resistance, create superior color retention and reduce unsightly weathering. Our multi-point locking systems provides superior performance during high winds.

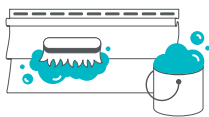

**4 Virtually maintenance free.** Cleaning is easy with mild soap and water from a garden hose. ProVia® vinyl siding products virtually eliminate the hassles of ongoing maintenance found in other cladding products resulting in lower long-term costs.



**5 Immune to moisture damage.** You never have to paint or caulk to protect ProVia® vinyl siding from water. Unlike wood and fiber cement, our siding is engineered with high-grade weathering defenses that enhance the inherent water resistance of vinyl and ensures moisture management for your home's exterior.



CERTIFICATION PROGRAM

**6 Performance is certified and sustainability is documented.** Products manufactured by ProVia® are certified and independently verified to meet or exceed industry quality and performance standards. In addition, vinyl siding's "green" attributes beat fiber cement and brick while rivaling cedar siding in overall green performance.

# BOARD 'N BATTEN

SUPER POLYMER VERTICAL SIDING



"To serve, by caring for details in ways others won't." It's not just our mission, but a way of letting our light shine every day at ProVia®. We continually strive to put these words into action by providing unmatched quality and service. The heart-shaped weep hole symbolizes each employee's commitment to devoting the utmost care, pride and quality into each building product we manufacture...it's The Professional Way.

Distributed by:



DOORS | WINDOWS  
SIDING | STONE | ROOFING  
[provia.com](http://provia.com)

© 2026 ProVia  
H-MK-20950-26 | 03/26



ON COVER: CedarMAX 12" BnB IN WHITE